

HOCHIKI CDX MARINE DETECTOR RANGE INSTALLATION INSTRUCTIONS



Products Covered: SLR-E3M, SLR-E3NM, DCD-AE3M, DCD-CE3M, c/w YBN-R/6M Base

The Conventional Marine Detectors listed above all use the common mounting base YBN-R/6M which is electronics-free and features a third terminal for Remote Indicator output. The Marine Back Box (MBB-1) should be used in certain locations and conditions (see MBB-1 Instructions for further details).

Follow the guidelines below before installation and maintenance. Hochiki cannot guarantee a detector's performance if these guidelines are not followed.

Caution

Hochiki CDX Marine Detectors cannot be used to prevent fire itself; they are only intended to detect a certain characteristic of fire. The DCD marine range of detectors is used to detect changes in temperature and cannot detect smoke and other phenomena. When installing the detector, check that the location of each one has been planned according to appropriate fire regulations or recommendations. Certain actions can cause permanent damage to the detector, and if subjected to any of the following, it should not be used:

Situations in which condensation exists	Smoke detectors only
Situations in which corrosive gases exist	All detectors
Impact or shock	All detectors
Situations in which obstacles exist, which could impede airflow to the detector	All detectors
Situations in which dust or steam exist	Smoke detectors only
Disassembly and re-assembly (except chamber replacement of photoelectric smoke detectors)	All detectors
Touching the thermistor located in centre of detector	Heat detectors only

If in any doubt, always refer to relevant certification regarding appropriate detector use.

If damage is suspected after a fire has occurred, the detector should be replaced. After installation, all detectors on the fire alarm system should be tested to confirm correct operation. Only suitably trained engineers should carry out installation and maintenance. The detector must be subject to periodic maintenance during regular service visits. This period should be outlined in the appropriate standards or recommendations. If there are no such standards existing, Hochiki recommend that the minimum period of maintenance should be one year and that the following should be taken into account:

- A regular operation test should be performed.
- A visual check for staining and mechanical damage should be made.
- Operation should only be checked by equipment that is capable of exceeding the required detection threshold.
- Detector operation should not be tested with a naked flame or open fire.

A dust cover is included with the detector to prevent contamination during installation. **The dust cover must be removed for the detector to operate.**

Head Locking Mechanism

Remove tab carefully using a pair of pliers

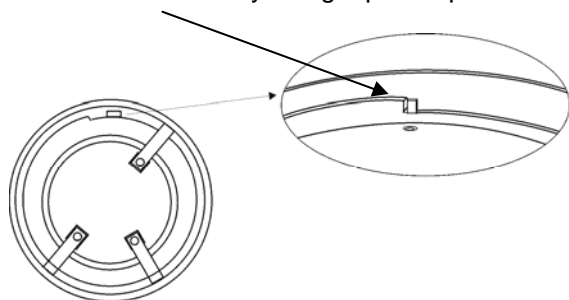

The CDX range of Marine Detectors can be locked onto the base by removing a plastic lug on the underside of the Detector. The Detector can then only be removed by using a special Removal Tool (TSC-A100/ALG), which is available from Hochiki Europe.

Wiring

The wiring diagram for the conventional marine detector base should be made as shown.

A: Zone (+), B: Zone (-), C: Cable Screen

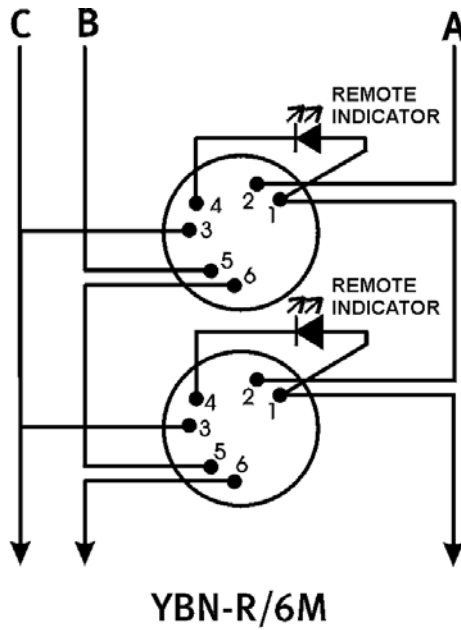

CDX MARINE DETECTOR RANGE



**CONVENTIONAL MARINE
HEAT DETECTORS
DCD-AE3M & DCD-CE3M**

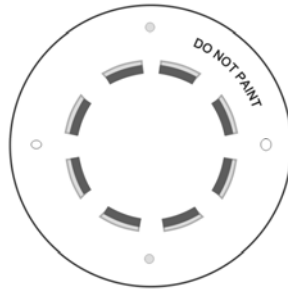
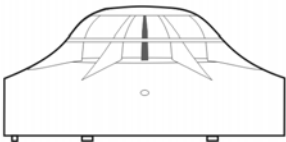

**CONVENTIONAL MARINE
PHOTOELECTRIC
SMOKE DETECTOR
SLR-E3M**

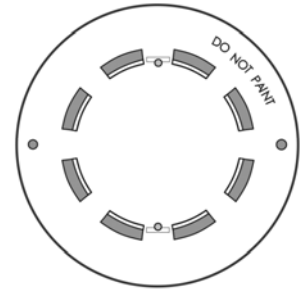
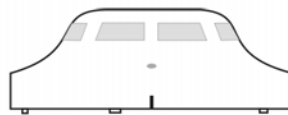

**CONVENTIONAL MARINE
PHOTOELECTRIC
SMOKE DETECTOR
SLR-E3NM**

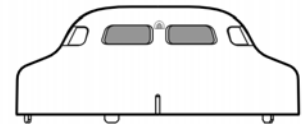

A list of compatible Control Panels is available on request.



Hochiki Europe (UK) Ltd
Grosvenor Road, Gillingham Business Park,
Gillingham, Kent, ME8 0SA, England
Telephone: +44(0)1634 260133 Facsimile: +44(0)1634 260132
Email: sales@hochikieurope.com
Web: www.hochikieurope.com

Hochiki Europe (UK) Ltd. reserves the right to alter the specification of its products from time to time without notice. Although every effort has been made to ensure the accuracy of the information contained within this document it is not warranted or represented by Hochiki Europe (UK) Ltd. to be a complete and up-to-date description. Please check our web site for the latest version of this document.